

## MULTIPLE MEMBER ENGINEERED WOOD BEAMS

### CONNECTION DETAILS

The FlatLOK Structural Wood Fastener has been designed specifically for use in joining multiple-ply structural wood beams. Using an impact driver, standard corded or cordless 1/2" low speed/high torque drill, install screws into the side of the outermost ply. As the thread fully engages the final ply, allow the underside of the washer head to pull the plies firmly together. Refer to the information in this bulletin for proper fastener size selection and fastening pattern.



### FASTENER SIZE SELECTION

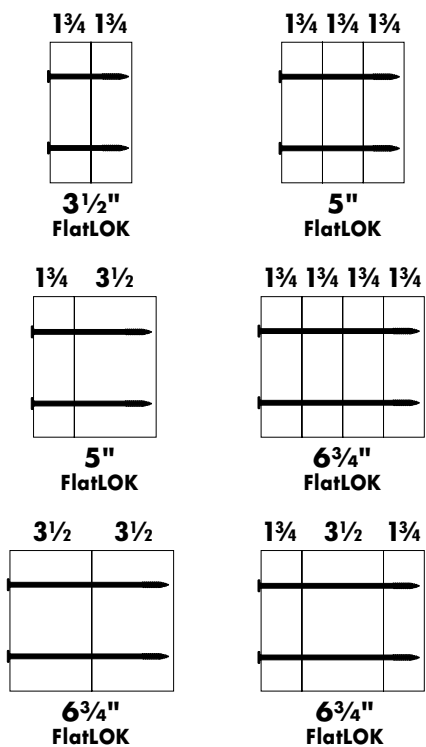

### FASTENER IDENTIFICATION

For easier selection and post-installation inspection, all FlatLOK fasteners carry an identifying head marking.

FlatLOK 3 1/2" . . . F3.5  
 FlatLOK 5" . . . . . F5.0  
 FlatLOK 6 3/4" . . . F6.7

### MINIMUM SPACING REQUIREMENTS

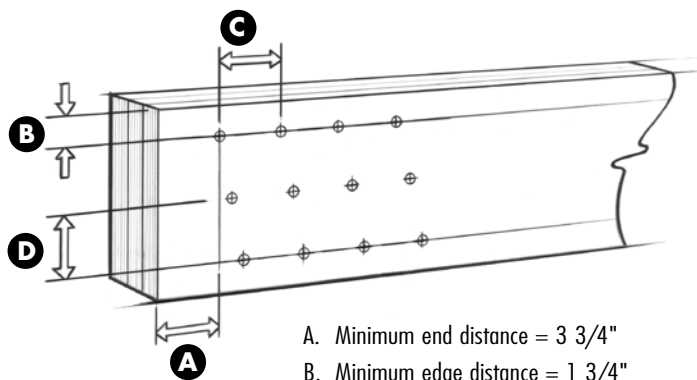

- A. Minimum end distance = 3 3/4"
- B. Minimum edge distance = 1 3/4"
- C. Minimum spacing between fasteners in a row = 3 1/2"
- D. Minimum spacing between rows of fasteners = 5/8"

### GENERAL GUIDELINES

- Beams wider than 7" require special consideration by a design professional. The values on the next page do not apply.
- Excessively warped or curved LVL should never be forced into alignment by use of clamps, screws or bolts as splitting may occur, potentially decreasing the carrying capacity of the beam.
- To avoid damaging the beam, fastener heads must not be countersunk.
- For applications other than those listed on this bulletin, a Professional Engineer (PE) may be consulted to determine proper connection design. For additional engineering data and technical assistance, please contact FastenMaster Technical Support at 800-518-3569 or visit our website at [www.FastenMaster.com](http://www.FastenMaster.com).



**Effective January 1, 2015.** Please reference our website to ensure that you are using the most up to date version.

153 BOWLES ROAD, AGAWAM, MA 01001

413-789-0252

800-518-3569

[WWW.FASTENMASTER.COM](http://WWW.FASTENMASTER.COM)

**FASTENING PATTERN**

**Top Loaded Beams**

Where all floor joists sit on the beam, fasteners should be spaced two every 24" on center in a staggered pattern as shown.

For beam depths of 18" or more, this pattern should be increased to three fasteners every 24" on center.

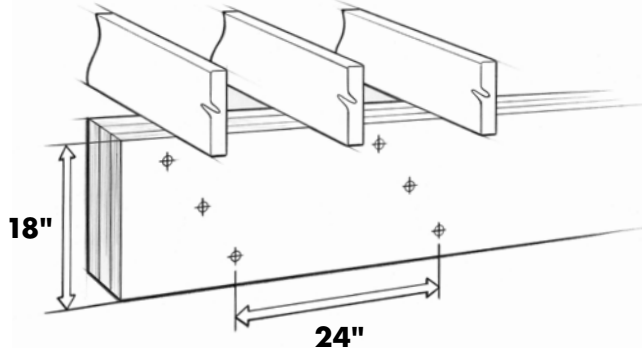
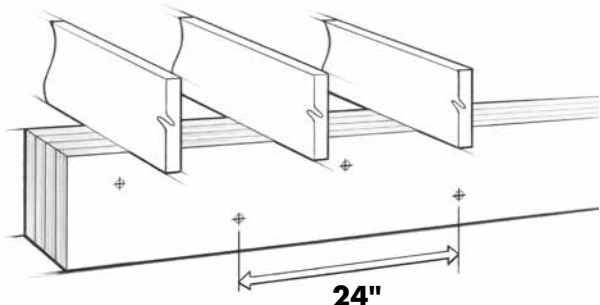

**Side Loaded Beams**

Where floor joists are joined to the side of the beam (typically using a joist hanger), this load chart must be used to establish the proper pattern based on the design load as determined by the engineer and noted on the plans.

**Assembly Type**

- Allowable loads in this table were calculated using design values determined through individual and system testing to ICC-ES AC-233 in engineered wood having a specific gravity of 0.50 or greater.
- The uniform loads in this table relate only to the capacity of the fastener to transfer shear loads between plies. The capacity of the EW beam may be less and should be checked against the manufacturer's literature.
- Values listed reflect 100% stress level ( $C_p=1.0$ ). The designer may apply adjustment factors to increase or decrease these loads per 2005 NDS based on conditions for each assembly.
- To minimize rotation, 7" wide beams shall be side loaded only when loads are applied to both sides of the beam with the lesser loaded side bearing at least 25% of the overall design load.
- Assumes that fasteners may be installed in the weakest condition, where greatest loads are applied to pointed side of the fastener.

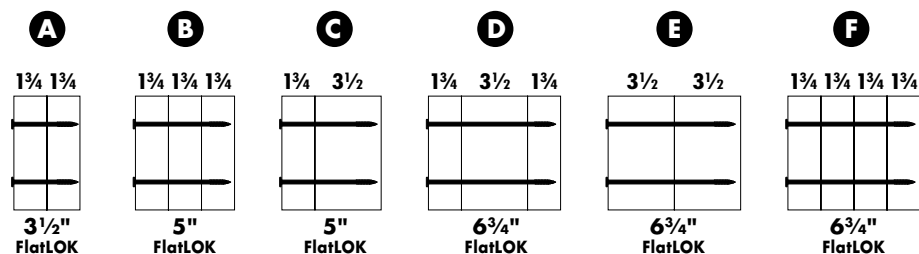

FLATLOK	NO of SCREWS	SPACING BETWEEN ROWS	ALLOWABLE SIDE LOADS BY ASSEMBLY TYPE					
			A	B	C	D	E	F
3 1/2"	2	24"	660					
	2	19.2	830					
	2	16	990					
	3	24"	990					
	3	19.2	1240					
	3	16	1490					
5"	2	24"		490	490			
	2	19.2		620	620			
	2	16		740	740			
	3	24"		740	740			
	3	19.2		920	920			
	3	16		1110	1110			
6 3/4"	2	24"				440	660	440
	2	19.2				550	830	550
	2	16				660	990	660
	3	24"				660	990	660
	3	19.2				830	1240	830
	3	16				990	1490	990